

Proportional pressure reducing valves of the series VMY allow the variable adjustment of the reduced pressure from 0 bar up to the nominal pressure.

The valve consists of a spool type main stage and a proportionally operated pilot stage. The desired pressure can be variably set corresponding to the command signal specified on the amplifier. The proportional solenoid converts the current of the amplifier into force on the valve poppet of the pilot stage.

Typical applications are pressure systems, test equipment, or counterweight systems. The optimum performance can be achieved in combination with the digital amplifier module PCD00A-400 for open loop systems or with PWDXXA-40* for closed loop systems.

Function VMY*K06

With the proportional solenoids de-energized the main spring forces the main spool into the neutral position. Port A is connected to port T. Thus the reduced pressure only depends on the back pressure in the external drain pipe and/or the tank pressure and can accordingly be reduced down to 0 bar. The pressure present in the P line delivers the pilot oil to the pilot stage via a flow control valve.

When the proportional solenoid is energized, the pilot pressure is increased in the pilot pressure area, and the main spool moves against the spring until the connection P - A opens. The regulation of the reduced pressure on connection A takes place by the constant comparison of the actual pressure and the reference pressure of the pilot stage.



VMY*K06

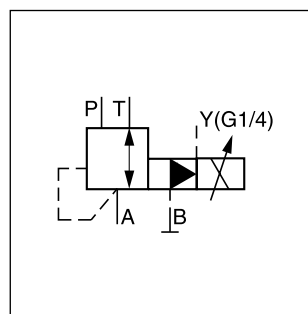

VMY*K06

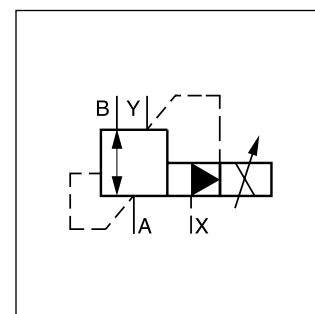

VMY*K10

4

VMY*K06N

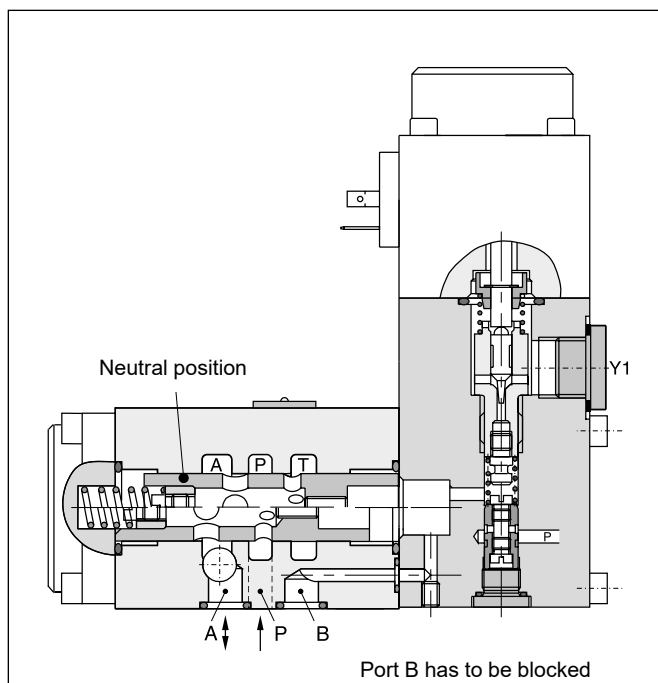

VMY*K10

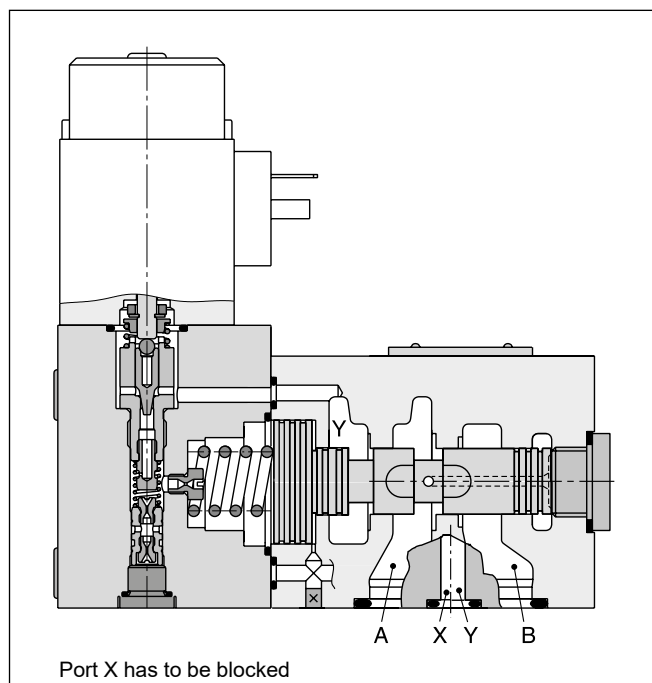

Ordering Code / Technical Data

Ordering code

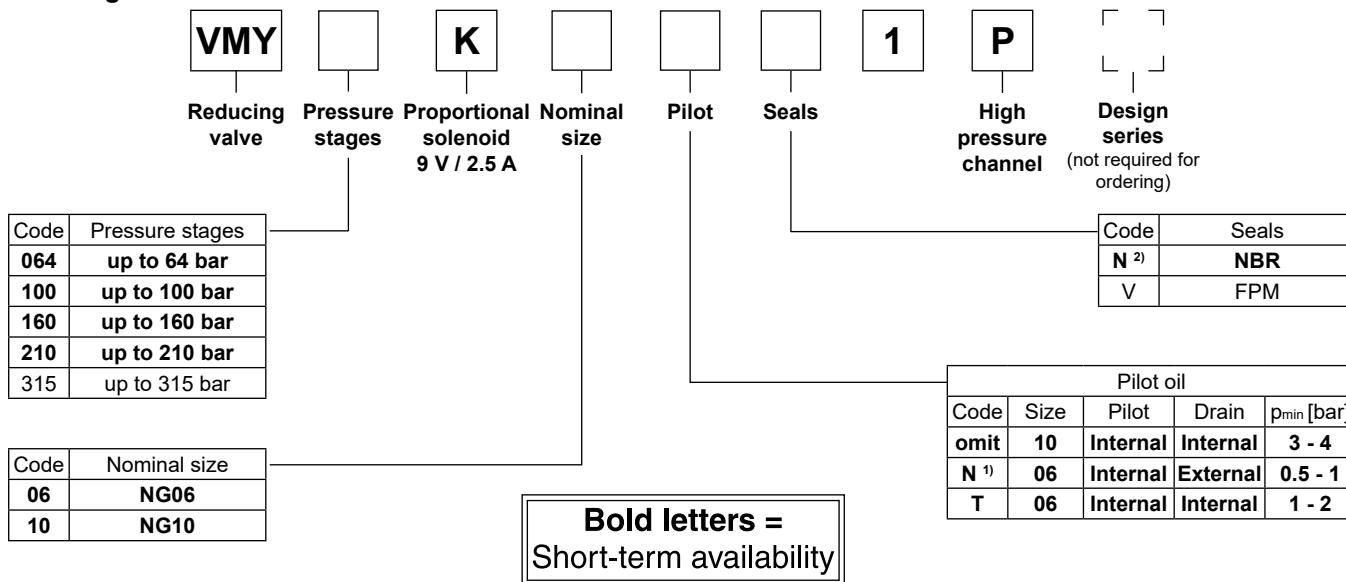

4

Technical data

General	
Design	3 way proportional reducing valve, pilot operated, spool design
Nominal size	06 (DIN NG06/CETOP 03/NFPA D03) 10 (DIN NG10/CETOP 05/NFPA D05)
Interface	Subplate mounting according to ISO 5781
Actuation	Proportional solenoid
Mounting position	unrestricted
Ambient temperature [°C]	-20 ... +60
MTTF _D value [years]	75
Weight [kg]	2.8 5
Hydraulics	
Max. operating pressure [bar]	Size 06: Ports P, A 315; Port T, Y depressurized; port B has to be blocked Size 10: Ports A, B 350; Port Y depressurized; port X has to be blocked
Pressure stages [bar]	64, 100, 160, 210, 315
Nominal flow [l/min]	40 160
Fluid	Hydraulic oil according to DIN 51524
Viscosity permitted [cSt] / recommended [cSt]	20 ... 400 30 ... 80
Fluid temperature [°C]	-20...+70 (NBR: -25...+70)
Filtration	ISO 4406; 18/16/13
Linearity [%]	See characteristic pressure curves ±3.5 at > 15 % p _{nom}
Repeatability [%]	<±2
Hysteresis [%]	<3
Response time [ms]	<150 <200
Electrical	
Duty ratio [%]	100 ED
Protection class	IP65 in accordance with EN 60529 (with correctly mounted plug-in connector)
Nominal voltage [VDC]	9
Max. current [A]	2.7
Nom. current [A]	2.5
Ambient temperature [°C]	-20...+70
Coil resistance [Ohm]	-2.1 (at 20 °C)
Solenoid connection	Connector as per EN 175301-803
Power amplifier, recommended	PCD00A-400

¹⁾ Connection on port Y1 or Y2.

²⁾ Not for NG06.

NG06 Characteristic pressure lines $p = f(U_{set})$

Setting range max. 64 bar

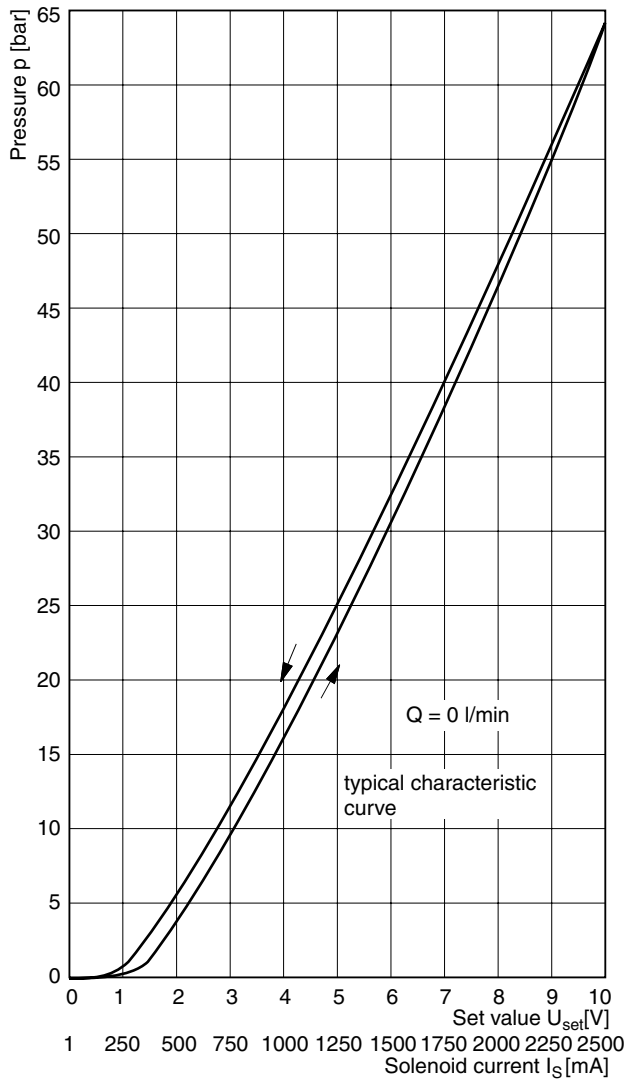

Setting range max. 210 bar

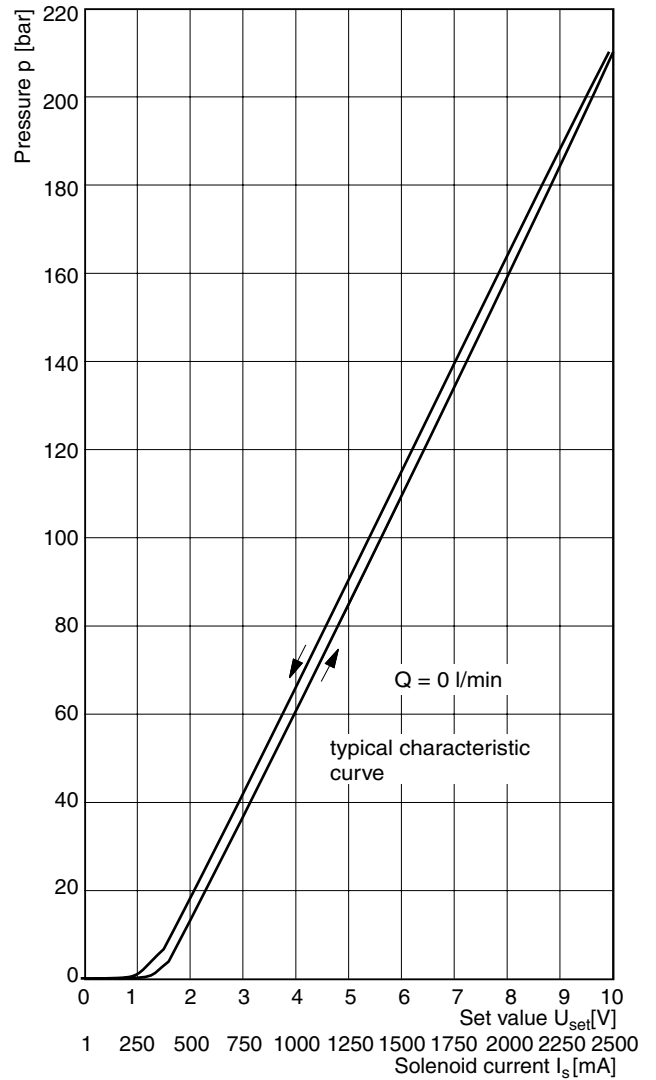

4

NG06 p/Q characteristics

Setting range max. 64 bar

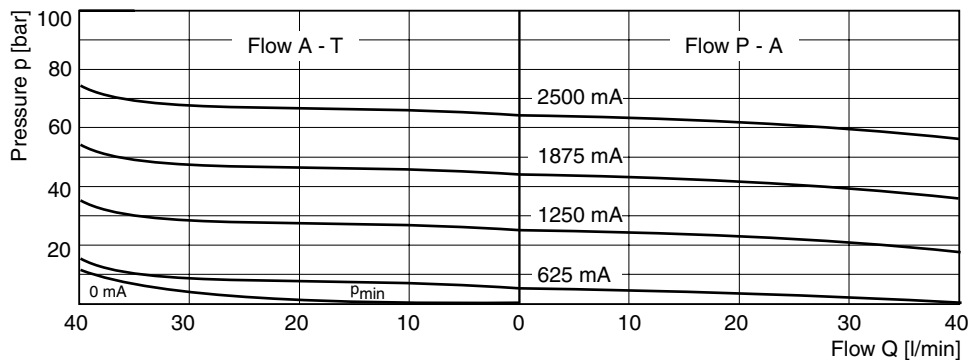

All characteristic curves measured with HLP46 at 50 °C.

NG06 p/Q characteristics

Setting range max. 100 bar

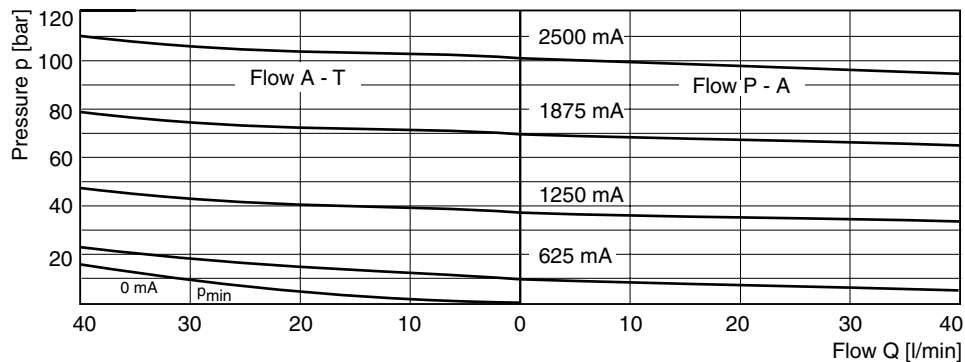

4

Setting range max. 160 bar

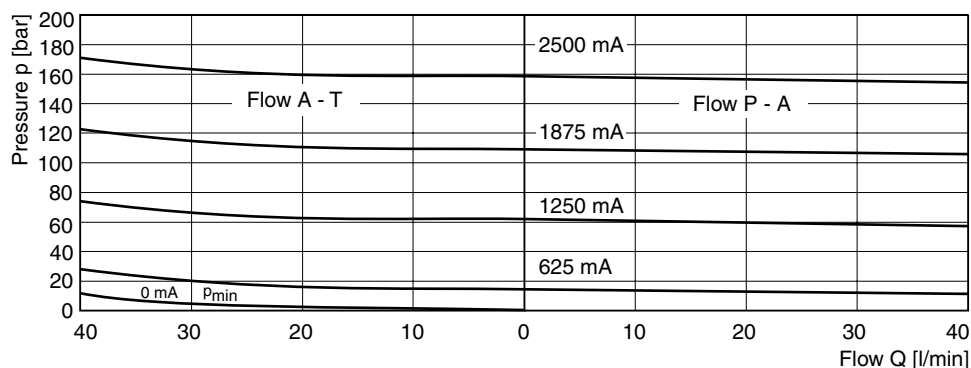

Setting range max. 210 bar

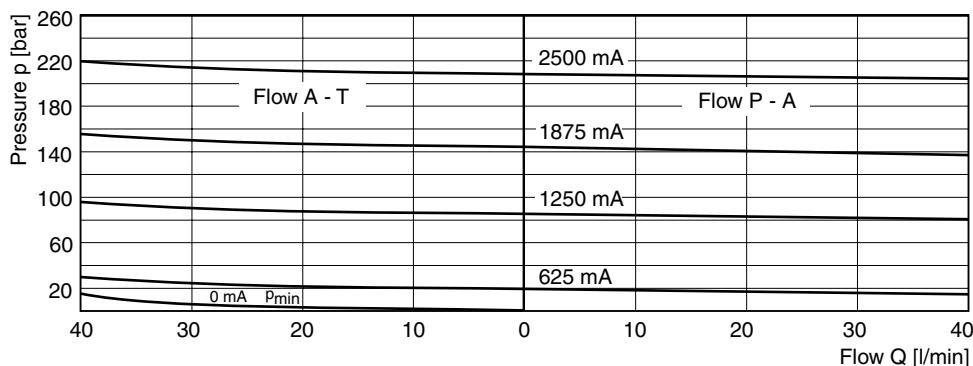

Setting range max. 315 bar

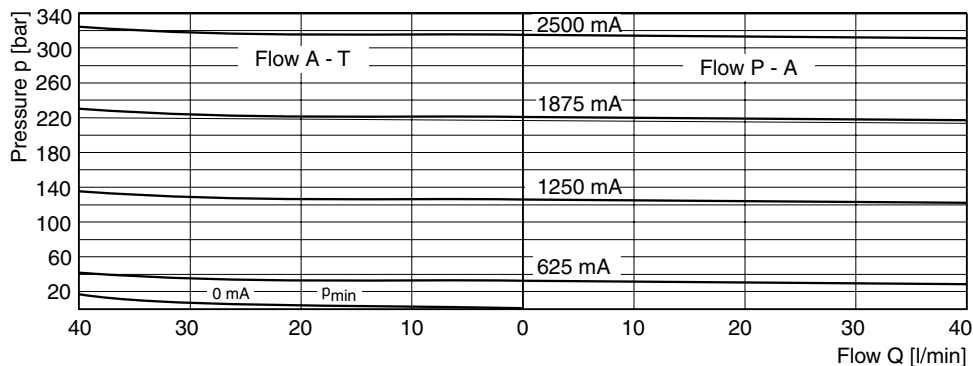

All characteristic curves measured with HLP46 at 50 °C.

NG10 p/Q characteristics
 for pilot oil supply from high pressure channel P

Setting range max. 64 bar

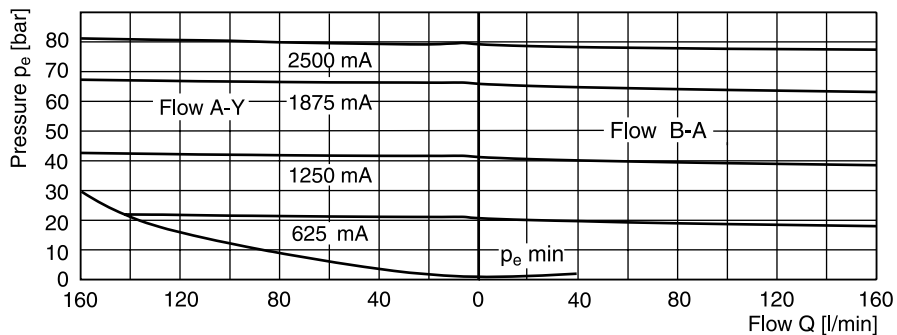

Setting range max. 100 bar

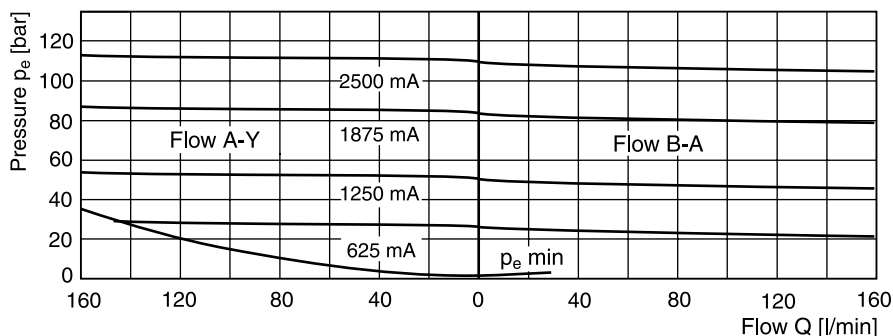

Setting range max. 160 bar

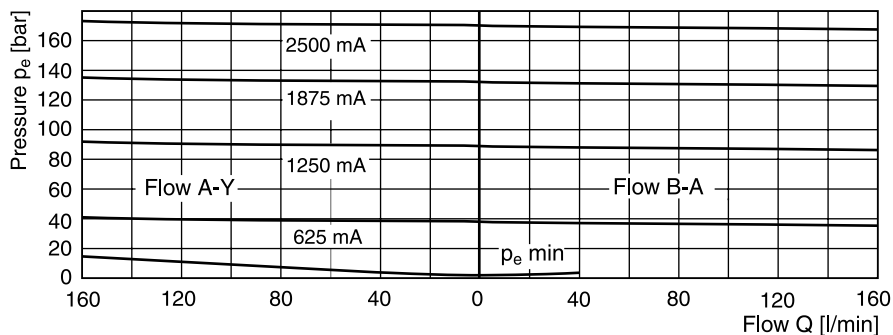

Setting range max. 210 bar

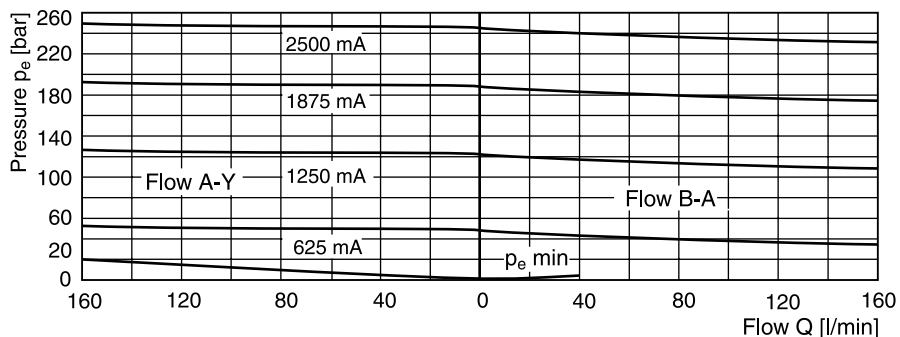

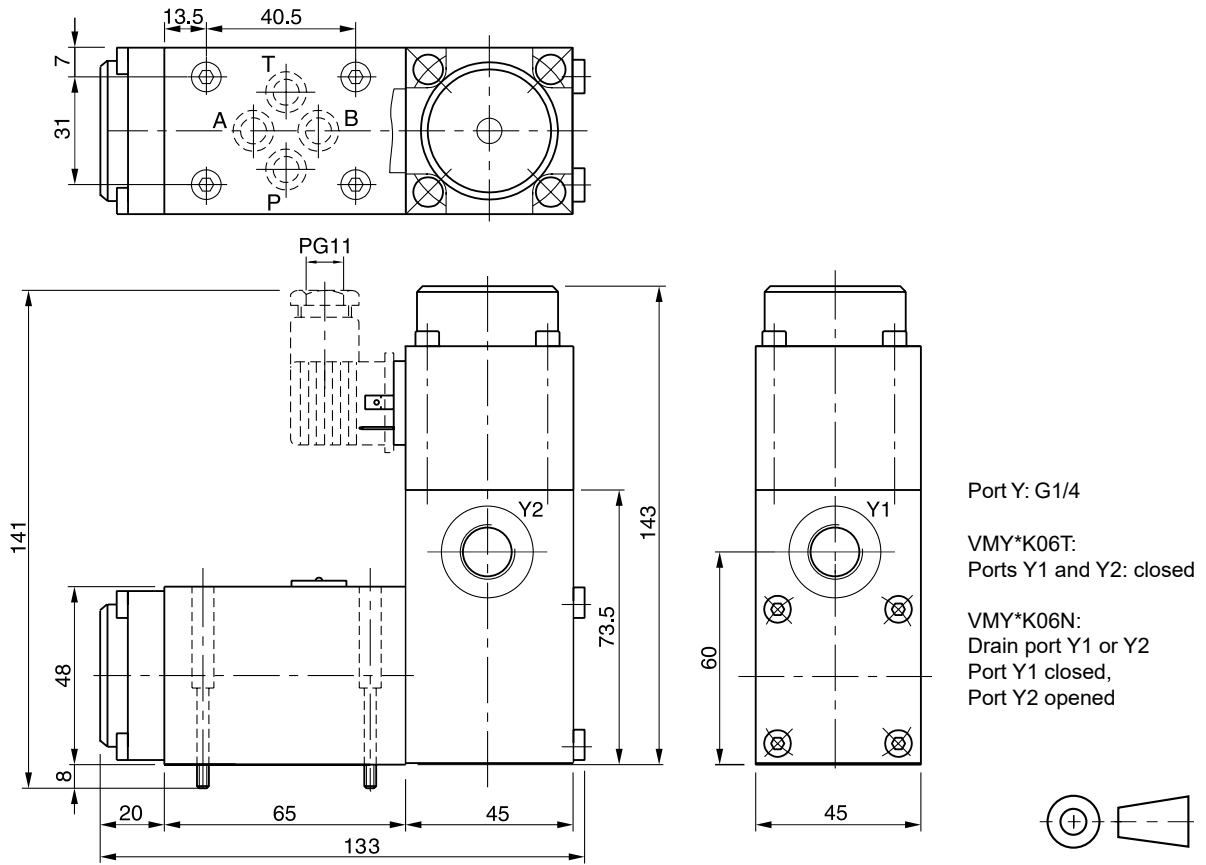

All characteristic curves measured with HLP46 at 50 °C.

NG06

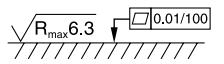

4

Surface finish	Bolt kit			
	BK375	4x M5x30 ISO 4762-12.9	7.6 Nm ±15 %	SK-VMY-L06-V

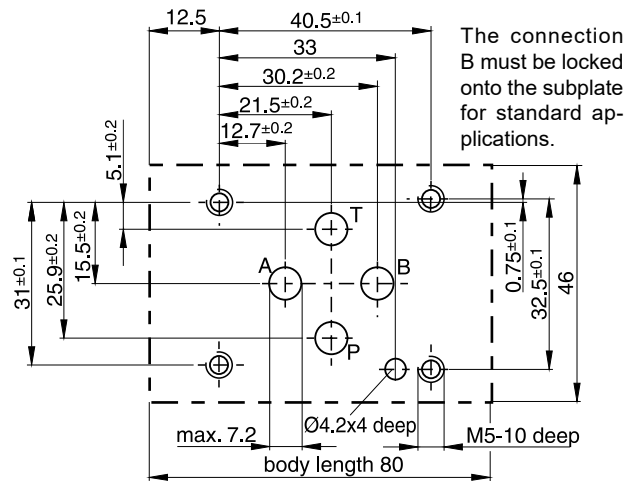

Mounting pattern ISO 5781-03-04-0-00

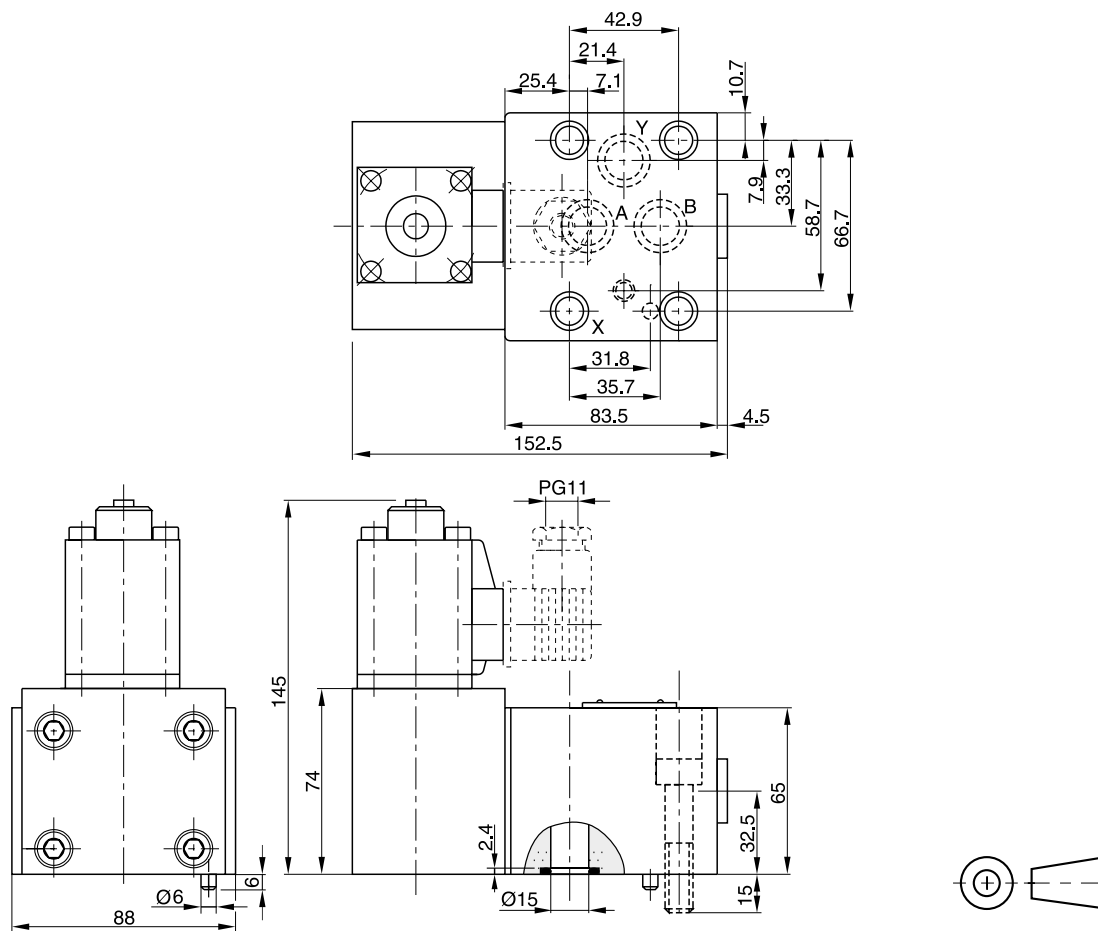

NG10

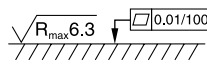

4

Surface finish	Bolt kit			 Kit FPM
	BK389	4x M10x50 ISO 4762-12.9	63 Nm ±15 %	SK-VB/VM-A10V

Mounting pattern ISO 5781-06-07-0-00 ¹⁾

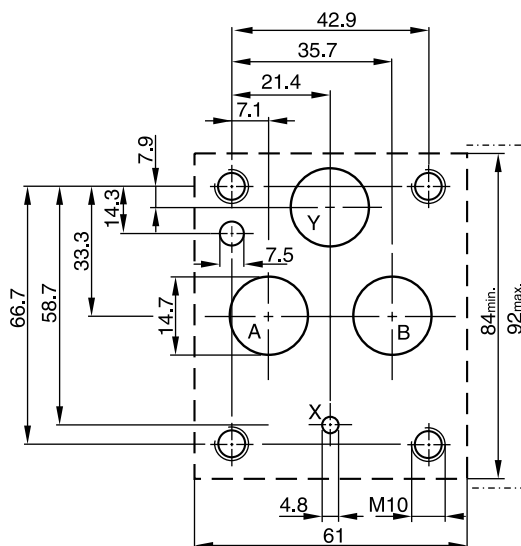

¹⁾ Deviating from ISO the Y port has Ø 14.7 instead of Ø 4.8.